

# DiveTracker™ Sport

SONAR Navigation System for Divers



**Owner's Manual**

***Rev 2B, August 2006***

Desert Star Systems, LLC

3261 Imjin Road

Marina, CA 93933

Phone: (831) 384-8000

FAX: (831) 384-8062

[www.desertstar.com](http://www.desertstar.com)

Diving is a dangerous and potentially life threatening activity. DiveTracker™ Sport must only be used by trained divers.

Despite all care, DiveTracker™ Sport can fail unexpectedly. To reduce your chances of death, serious injury, and damage to

property, never use DiveTracker™ Sport or any other method or instrument as your sole means of navigation. Always have at least one other means of navigation available to you.

Your Safety is Your Responsibility; Use Common Sense and Good Judgment!

## LIABILITY DISCLAIMER

By purchasing or using DiveTracker™ Sport, it is agreed and understood that in no event will Desert Star Systems or any of its representatives be held liable for any personal injuries or death or damages to property resulting from its operation or for any other damages whether direct, indirect, or consequential, even if Desert Star Systems has been advised of such actual or potential damages. Desert Star Systems dive products are authorized for use only by properly trained divers. The user must understand that the products are liable to sudden failure. Diving is an inherently dangerous activity, and proper safety procedures demand that the diver never rely solely on just the DiveTracker™ Sport or any other single instrument, method or mechanism for his/her safety or the safety of property.

*Thank You for Purchasing DiveTracker™ Sport!*

Your DiveTracker™ Sport is a state-of-the-art underwater navigation product. This instrument is designed and manufactured in the United States of America to the highest standards of quality and performance.

This booklet will show you how DiveTracker™ Sport works, how to operate and maintain it, and how to interpret the information provided by the system. Please read this booklet carefully and in its entirety before diving with DiveTracker™ Sport. Only by doing so will you be able to obtain the full potential of the system and operate it safely.

Be aware that diving is a dangerous activity. DiveTracker™ Sport is designed to help you, the well-trained and certified diver, to navigate under water. If you are not a certified diver, obtain proper training before using the product or else return your DiveTracker™ to the place of purchase for a full refund.

Your DiveTracker™ Sport is an aid to navigation, and not a piece of life support gear. As such, it is unlikely that you will be hurt by the instrument itself any more than you might by a flashlight or any other object of similar shape, size, and weight. The main danger in the use of DiveTracker™ Sport lies in an over-reliance from the information provided by it, just as when an electronic system might fail spontaneously and unexpectedly due to component failure. As a SONAR based system, it can fail at any time due to changing environmental (acoustic) conditions.

For these reasons, you must never rely on DiveTracker™ Sport or any other instrument, tool or method as your sole means of navigation. Always dive in such a manner that the failure of DiveTracker™ Sport will not put you, your dive partners or property at the risk of injury or death!

If you heed these warnings, DiveTracker™ Sport will greatly increase the efficiency and enjoyment of your dives. To a degree, and supposing proper usage, it can also increase your diving safety.

Congratulations on your purchase of this advanced and unique system! We are sure you will find DiveTracker™ Sport a very worthwhile investment.

## About this Manual

This manual is designed for you, the user of DiveTracker™ Sport. Within it, you will find information and advice on how the system works, how to use it, how to maintain it, and how to get the most performance out of it.

Throughout this manual, you will find information highlighted by key words and the placement in either black or gray boxes. Please pay special attention to all information displayed in this manner. The following three boxes serve as a key to this information.

Information displayed under the word **WARNING** indicates a potentially hazardous situation that could result in serious death or injury. In all these cases the hazard is not caused by the product itself, but rather by the potential consequences of the exclusive reliance on the information presented (or not presented) by DiveTracker™ Sport. — Information displayed under the word **CAUTION!** indicates a situation that could result in damage to your DiveTracker™ Sport.

## 1. How Does DiveTracker™ Sport Work

DiveTracker™ is a SONAR (**S**ound **N**avigation and **R**anging) based navigation system. SONAR systems like DiveTracker™ Sport emit and receive high frequency sound. While light and most radio waves travel far worse in water than they do in air, sound actually propagates not only significantly faster but also much further in water than it does in air. For this reason, sound is used in many underwater applications. People use sound for things like fish finders, depth sounders, and detecting enemy war ships. Some marine mammals use it to navigate, to communicate, and even to inspect prey.

DiveTracker™ Sport also makes use of sound. The system consists of two components.

The transmitter or pinger emits sound pulses or 'pings' that propagate in all directions. When you point the receiver in the direction of the transmitter, it detects those pulses and indicates their

strength on the LED strip display. Just swim in the direction of the strongest signal to find your way back to the transmitter marked site (dive boat, anchor line, etc.). Notice the strength of the signal to obtain an estimate of the transmitter's distance.

If you have done night dives before, you probably know the practice of tying a strobe light to the anchor chain or lowering it over the side of the boat. As long as you are 'within range' of the strobe light, you can always find the direction back to the boat – or to any place that the strobe is attached to. By judging the intensity of the strobe light, you can also estimate its distance.

DiveTracker™ Sport relies on the very same principle – except that sound energy instead of light is used as the signaling medium. The DiveTracker™ Sport transmitter is the equivalent of the strobe light, whereas the DiveTracker™ Sport receiver is the equivalent of your eyes seeing the strobe flashing.

However, there are two significant advantages to the use of sonar instead of light.

- The range of a strobe light is determined by water visibility or turbidity. In clear water, the strobe may work to a few hundred feet. If the water is turbid, you will be restricted to just a few feet. DiveTracker™ is not affected by water turbidity and will typically give you a range of 2,000 feet.
- Strobe lights work well at night, but not at daytime when the strobe light is overpowered by sunlight. DiveTracker™ Sport will work just as well during the day as it does at night.

Of course, SONAR systems like DiveTracker™ Sport have limitations too. Sound waves can be absorbed, reflected, and refracted. Excessive noise in the water can raise a 'curtain' that the systems cannot penetrate and sonar echoes can lead you in wrong directions. DiveTracker™ Sport includes a number of mechanisms to deal with these problems. These mechanisms allow the system to operate under most conditions, but they certainly don't make it perfect.

Refer to the chapter 'Beware of the Sonar Gremlins' for some guidance on the things that can go wrong and how to deal with them. Please read it carefully. Again, if you hope to stay alive, please never use DiveTracker™ Sport or any other instrument, tool or method as your sole means of navigation.

## **2. The DiveTracker™ Sport Hardware**

Your DiveTracker™ Sport system consists of two components. The DiveTracker™ Sport transmitter (DTS-TX) works as a 'sonar beacon', emitting sounds in all directions. The transmitter is used to 'mark' a site. The DiveTracker™ Sport receiver (DTS-RX) is typically carried by the diver. This unit picks up the sonar signals from the transmitter and tells you the direction and distance of the transmitter marked site.

### **2.1 The Transmitter (DTS-TX)**

The DiveTracker™ Sport transmitter is housed in a cylindrical PVC container. The red low-battery LED on the transmitter lights up when approximately 1/4 of the battery power is remaining. The transmitter is activated by a thumb wheel switch on the side of the housing. Align the ON indicator on the knob with the red mark on the housing to activate the transmitter. All other positions will switch the transmitter off.



**The DiveTracker™ Sport Transmitter (DTS-TX)**

The transmitter housing design has been changed. The transmitter now uses the same type of housing as the receiver. A picture of the new transmitter housing was not available at the time of print. The text reflects the new housing design.

Located on both the bottom end and the top end of the housing are eye rings. The eye ring on the top of the unit is normally used to secure the transmitter to a line. The line is lowered over the side of a boat, tied to an anchor line or is otherwise used to tie the transmitter to the location you wish to mark.

The eye ring on the bottom of the transmitter may be used to weigh down the transmitter in a strong current or to attach a floatation device in order to raise the transmitter up from an ocean floor mounting point.

The top of the DiveTracker™ Sport transmitter is occupied by a removable cap. The low-battery LED is visible through that cap.

The cap is held in place by a stainless steel snap-ring. To remove the cap, swivel the snap ring out. Then, squeeze it gently at either end until the ends of the ring can be removed from the mounting holes in the housing. Now remove the cap by pulling on the eyehook while wiggling it back and forth.

Located inside the DTS-TX housing is the electronics module, a six 'AA' cell battery pack and the SONAR transducer (the antenna of the transmitter). You will also notice a four small toggle switches mounted on the electronics module. These switches control the SONAR pulse repeat rate, as described in section 5.1.

The SONAR transducer is potted into the bottom of the transmitter housing. This transducer will emit sonar signals in all directions other than 'up'. The 'up' direction is blocked by the electronics cavity of the transmitter.

## 2.2 The Receiver (DTS-RX)

The DiveTracker™ Sport receiver (DTS-RX) is housed in a cylindrical PVC chassis.

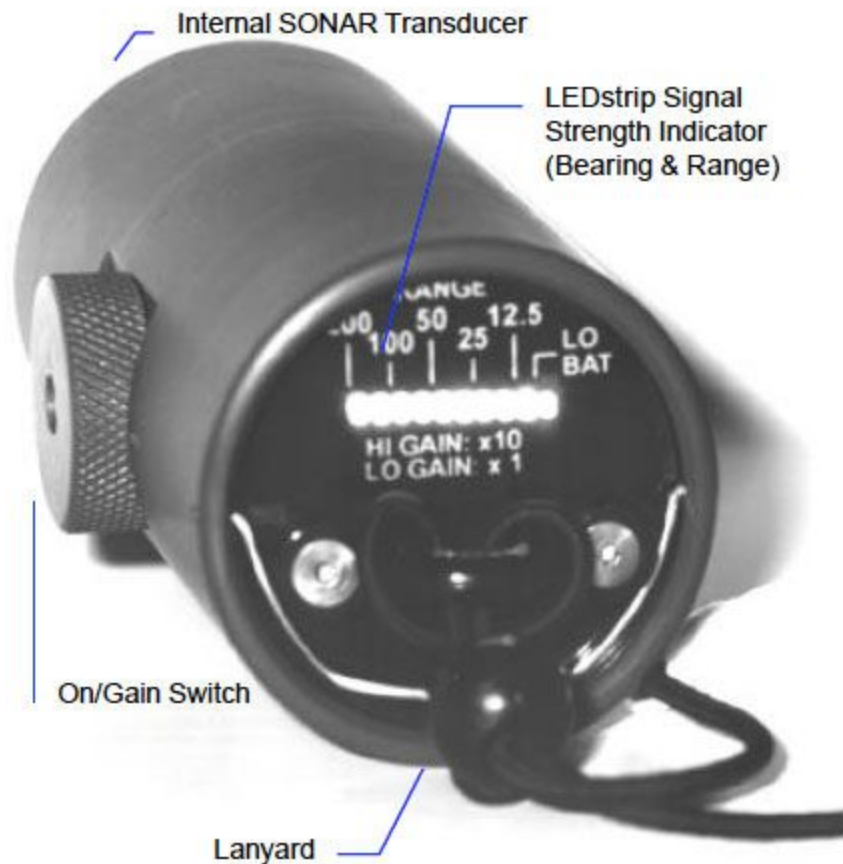

## The DiveTracker™ Sport Receiver (DTS-RX)

Located on the left side of the housing is a four-position thumb wheel switch. The function of that switch is as follows.

### Receiver Thumb Wheel Switch Operation

- The receiver is switched off whenever either of the two OFF indicators on the knob is aligned with the red mark on the housing.
- The receiver is in low-gain mode when the LO indicator on the knob is aligned with the red mark on the housing. In low-gain mode, the receiver sensitivity is reduced in order to facilitate operation at close range (less than 200 feet).
- The receiver is in high-gain mode when the HI indicator on the knob is aligned with the red mark on the housing. In high-gain mode, the receiver is at full sensitivity in order to facilitate operation at far range (200-2000 feet).

The top of the DiveTracker™ Sport receiver is occupied by a removable cap. The cap contains the LED strip signal-strength indicator and the associated range scale. Also located on the cap is an eyehook. The eyehook is used to connect the lanyard (supplied) to the housing.

The cap is held in place by a stainless steel snap-ring. To remove the cap, swivel the snap ring out. Then, squeeze it gently at either end until the ends of the ring can be removed from the mounting holes in the housing. Now remove the cap by pulling on the eyehook while wiggling it back and forth.

The inside of the unit reveals the electronics module and the battery cavity which accommodates a 9V alkaline battery.

Two small toggle switches are mounted on the electronics module. These switches allow you to select 'extended range' operation and to select the 'persistence' of the LED strip display. Normally, these switches will not have to be touched. Refer to section 5.2 for a detailed description of the switch functions.

Located in the bottom of the unit is the receiver's directional SONAR transducer. The transducer is the antenna of the receiver. It picks up the SONAR signals emitted by the DiveTracker™ Sport transmitter.

The SONAR transducer is directional. It only senses signals that originate from sources located within its conical beam pattern. The beam has its center straight out the bottom of the receiver housing and extends about 15 degrees in all directions from that centerline. This conical beam shape is similar to that of a flash light.

The directional nature of the beam allows you to determine the direction of the DiveTracker™ Sport transmitter receiver by pointing the receiver around until the direction producing the strongest signal is found.

### 3. Operating DiveTracker™ Sport

Operation of DiveTracker™ Sport is straightforward.

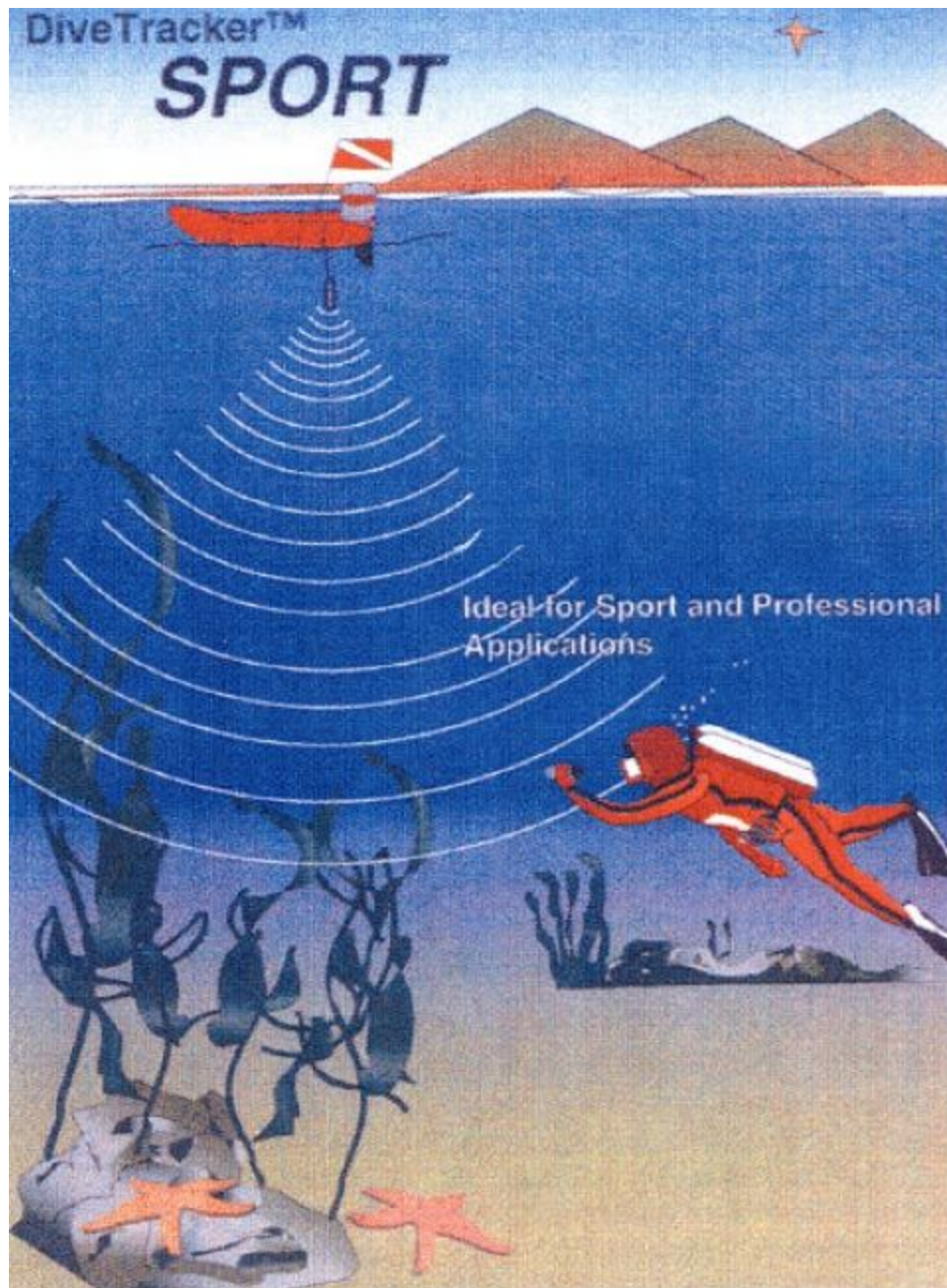



## Use of DiveTracker™ Sport to Mark A Dive Boat

### **Step One: Mount the DiveTracker™ Sport Transmitter**

Activate the transmitter and mount it on any underwater site you wish to 'mark'. If that site is your dive boat, lower the transmitter over the side of the boat or attach it to the anchor line. If you want to use the unit to mark your favorite lobster hole, mount the transmitter near that lobster hole.

In any case, mount the transmitter so that it is well clear of any obstacle (rocks, the ship hull, kelp, etc.). The idea is to have a 'line of sight' situation between the transmitter and diver mounted receiver whenever possible. If there is a thermocline at your dive site and you expect to dive underneath this thermocline, make sure that the transmitter is mounted underneath the thermocline too! As a rule of thumb, lower the transmitter at least ten feet into the water.

There is a mounting ring on either end of the DiveTracker™ Sport transmitter. When you deploy DiveTracker™ Sport over the side of the boat, attach a line to the top mounting ring (the one on the cap).

Even though the transmitter is negatively buoyant, you may still find it being pushed horizontally by a strong current and end up close to the surface. This is undesirable. Attach a weight to the bottom-mounting ring to make your transmitter heavier and force it down.

If you secure the transmitter to the ocean floor, use the opposite technique. Leave the line attached to the top mounting ring but attach a small floatation device (sturdy plastic or glass bottle, fishing net float etc.) to the bottom-mounting ring. The transmitter can now 'float up' and be clear of any obstacles.

Make sure the transmitter is activated and the receiver is properly operating before you start your dive. Check the low battery LED. If the LED is on, the transmitter may not have enough battery power to operate for the duration of the dive

### **Step Two: Find the direction and distance of the transmitter**

Secure the lanyard of the receiver to your wrist or otherwise mount the unit on your dive gear so that it is readily accessible. Now, start your dive.

Whenever you want to find the location of the transmitter, switch the DiveTracker™ Sport receiver on by rotating the knob on the left side of the unit so that HI is aligned with the red line. The receiver is now activated and is in high sensitivity mode. Hold the receiver horizontally at eye level. Hold it so

that its bottom end (the end with the label) points away from you and you can see the LED strip display.

Now slowly rotate your body around its axis so that the receiver can scan your surroundings for sonar energy. Watch the LED strip display. Once LEDs start flashing rhythmically, your receiver is picking up the transmitter signal. The more LEDs flash, the stronger the received signal is. The most likely direction of the transmitter is the one that causes the greatest number of LEDs to flash.



The LED strip Indicates Direction and Distance of the Transmitter

It is important that you scan a full (360 degree) circle. This is necessary because you may well see echoes in addition to the direct signal. Again, the direct signal is in most cases the strongest signal.

If you are close to the transmitter (less than about 200 feet), you may see equally strong signals coming from several directions. In this case, turn the receiver knob such that **LO** is aligned with the red line. This reduces the receiver sensitivity by a factor of ten (20 decibel). Repeat the full circle scan and once more use the strongest signal as your indicator of the direction of the transmitter.

To conserve battery power, remember to turn the receiver OFF after every use.

### 3.1 Measuring Distance

In the previous chapter, you have seen how the DiveTracker™ Sport receiver is used to find the direction of the transmitter. You can also use the unit to estimate the distance of the transmitter!

DiveTracker™ Sport can estimate the distance of the transmitter by measuring the strength of the received signal. SONAR signals just like sound on land get progressively weaker the further you are from the source of that sound. Engineers commonly assume that SONAR signals will be reduced to

a quarter of their strength for every doubling of the distance between the transmitter and the receiver. This is known as 'spherical spreading loss'.

DiveTracker™ Sport makes use of this theory to estimate distance. For this purpose, a range or distance scale is printed on the DiveTracker Sport receiver cap above the LED window. Once you have located the direction of the strongest signal, watch the range that is indicated above the last (right most) LED that lights up. The number tells you your approximate distance in feet. Multiply the indicated number by ten if you are in HI GAIN mode. Multiply it by one if you are in LO GAIN mode.

Measuring distance by looking at signal strength is a rather inaccurate and sometimes misleading science. For this reason, distance is indicated on the scale only in rough numbers. In most cases, you will be able to determine a doubling or halving of your distance (every two LED's indicate a double or half distance). However, in other cases you may find that Mother Nature has forgotten to read the science books and the signal stays at the same strength for a long time, actually gets greater with growing distance or drops of far more rapidly than expected. All this may cause you to appear to be at a greater or lesser distance than you really are.

Be careful! Do not take the distance readings as gospel but rather put about as much faith in them as you might in a long-range weather forecast. Over time, you will be able to interpret the numbers with growing confidence.

Also, make sure to read the chapter 'Beware of the Sonar Gremlins' to get a better idea about why and how things can go wrong.

## 4. Maintaining And Testing DiveTracker™ Sport

DiveTracker requires very little maintenance.

### DiveTracker™ Sport Maintenance

- Rinse DiveTracker™ Sport in fresh water after use.
- Replace the battery when the LOW BATTERY light on either unit comes on.
- Make sure the end cap of either unit is well secured before immersing DiveTracker™ Sport in water.
- Periodically check the O-ring of both units for any damage or debris.
- Test each DiveTracker™ Sport before every dive.

The biggest danger to your DiveTracker™ Sport is the risk of flooding. Both the transmitter and receiver are sealed through a single, reliable O-ring. You can avoid flooding by properly inspecting and cleaning the O-ring and seating surfaces before closing either unit. Refer to sections 4.1 and 4.2 for details. Because the risk of flooding depends on your level of care, we

cannot be held responsible for damage due to flooding and our warranty specifically excludes such damage. If DiveTracker™ Sport should ever flood, immediately remove the battery, and thoroughly rinse the unit in fresh water. Allow your DiveTracker™ Sport to dry before trying to operate it again.

To test the DiveTracker™ Sport receiver (DTS-RX), rotate the thumb wheel switch until HI is aligned with the red line on the housing. Look at the LED strip display and tap the bottom end of the housing with your finger or a pencil. Several LEDs should light up. If the **LO BAT** LED is lit, the battery is nearing the end of its life. Replace the battery. If no LED whatsoever lights up, your receiver may be missing the battery, the battery may be completely dead, or it may be inserted incorrectly. Check the battery and replace it with a fresh battery if necessary. Then, repeat the test.

To test the DiveTracker™ Sport transmitter (DTS-TX), rotate the thumb wheel switch to the **ON** position. Next, activate the DiveTracker™ Sport receiver and point it straight at the bottom of the transmitter housing. You should see several of the receiver LED strip elements light up. If a receiver is not available, hold the transmitter close to your ear. You should hear a periodic clicking sound. If the red low battery LED lights up, the battery is nearing the end of its life. Replace the battery. If the LED does not light up and you can't detect any transmit activity, your transmitter may be missing its battery. The battery may also be completely dead or it may be inserted incorrectly. Check the battery and replace it with a fresh battery if necessary. Then, repeat the test.

Changing the batteries on either unit requires opening the housing. Please follow the instructions in the next two sections.

## 4.1. Changing the Transmitter (DTS-TX) Battery

The DiveTracker™ Sport transmitter is powered by a set of six AA size alkaline cells. The cells are good for about one week (168 hours) of continuous operation. Replace the battery when the red LED on the transmitter housing lights up.

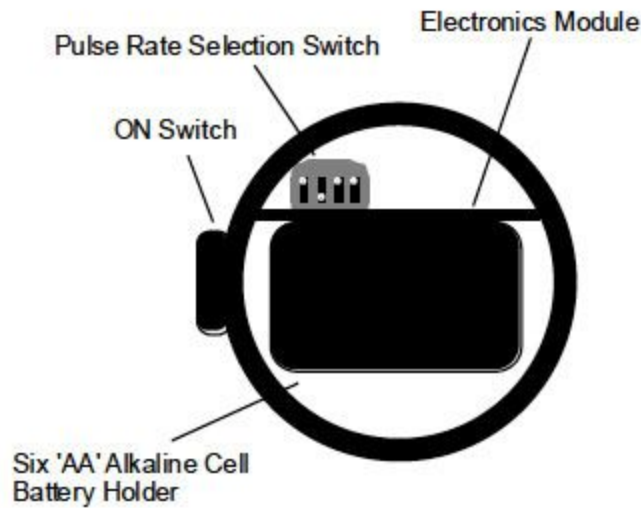

Internal View of the DiveTracker™ Sport Transmitter (DTS-TX)

To replace the transmitter battery, follow this procedure:

### Changing the Transmitter Battery

- Open DiveTracker™ Sport only in a dry, clean place. Make sure that the unit and your hands are dry.
- To open the transmitter, swivel the metal snap ring so it stands out from the unit.
- Gently squeeze the sides of the snap ring together and remove the ring from its two mounting holes.
- Hold onto the black plastic eye ring with your thumb and index finger. Pull gently on the eye ring while wiggling it back and forth until the front cap of the receiver is removed.
- Place your hand over the opening and hold the housing upside down. The six 'AA' cell battery pack will slide out.
- Insert a fresh set of 'AA' cells. Watch the battery polarity indicators (+ and -) on the battery holder. A wrongly inserted battery will not damage the unit but will prevent it from working. Be careful not to tear off the wire that connects the battery holder to the transmitter assembly.
- After you have replaced the batteries, re-insert the holder into the transmitter housing.
- Carefully inspect the O-ring on the housing cap and remove any debris.
- If the O-ring looks dry, remove it from its groove using the edge of a credit or certification card. Apply a thin film of silicone grease to the O-ring. Remove any debris from the O-ring groove and re-insert the O-ring in its groove.
- Remove any debris from the O-ring seating surface on the housing.
- Do not use the O-ring if it has been cut, nicked, or otherwise damaged.
- Rotate the front cap such that the two grooves line up with the mounting holes on the housing and the window in the front cap lines up with the LED strip.
- Re-insert the front cap by gently pushing down on it.

- Gently squeeze the snap ring and re-insert the ends in the two mounting holes.
- Swivel the snap ring back against the surface of the front cap.

After the unit has been re-assembled, test its operation by switching it ON. Hold the transmitter close to your ear. You should hear a periodic clicking sound coming from the bottom of the housing.

The DiveTracker™ Sport receiver is powered by a 9V alkaline cell. The cell is good for about six hours of continuous operation or about 720 position readings (at 30 seconds per reading). Replace the battery when the right most LED on the LED strip lights up. The LED is marked with the letters LO BAT.

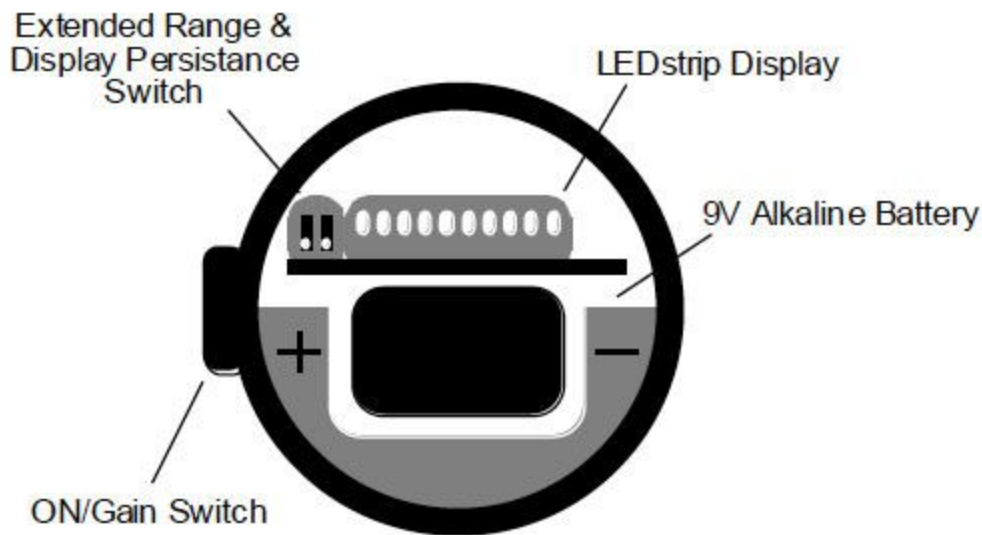

Internal View of the DiveTracker™ Sport Receiver (DTS-RX)

To replace the receiver battery, follow this procedure:

### Changing the Receiver Battery

- Open DiveTracker™ Sport only in a dry, clean place. Make sure that the unit and your hands are dry.
- To open the receiver, swivel the metal snap ring so it stands out from the unit.
- Gently squeeze the sides of the snap ring together and remove the ring from its two mounting holes.
- Hold onto the black plastic eye ring with your thumb and index finger. Pull gently on the eye ring while wiggling it back and forth until the front cap of the receiver is removed.
- Place your hand over the opening and hold the housing upside down. The 9V battery will slide out. • Insert a fresh 9V alkaline battery, contacts first, into the battery cavity. Watch the battery polarity indicators (+ and -) next to the battery channel. Insert the battery so

that the smaller contact is next to the '+' symbol and the greater contact next to the '-' symbol.

- A wrongly inserted battery will not damage the unit but will prevent it from working.
- Carefully inspect the O-ring on the housing cap and remove any debris.
- If the O-ring looks dry, remove it from its groove using the edge of a credit or certification card. Apply a thin film of silicone grease to the O-ring. Remove any debris from the O-ring groove and re-insert the O-ring in its groove.
- Remove any debris from the O-ring seating surface on the housing.
- Do not use the O-ring if it has been cut, nicked, or otherwise damaged.
- Rotate the front cap such that the two grooves line up with the mounting holes on the housing and the window in the front cap lines up with the LED strip.
- Re-insert the front cap by gently pushing down on it.
- Gently squeeze the snap ring and re-insert the ends in the two mounting holes.
- Swivel the snap ring back against the surface of the front cap.

After the unit has been re-assembled, test its operation by selecting the HI GAIN setting on the thumb wheel switch. Gently tab your finger against the bottom surface of the unit. Several LEDs on the LED strip should light up.

## 5. Advanced Operation Techniques

So far, you've learned how DiveTracker™ Sport works, how to operate it and how to maintain it. This chapter provides some additional information on advanced use of your DiveTracker™ Sport.

### 5.1 Marking Multiple Sites

Using your DiveTracker™ Sport, you can 'mark' any underwater site by simply attaching a DiveTracker™ Sport transmitter (DTS-TX) to it. In some cases, you may find it necessary to mark multiple sites yet still be able to distinguish between them. For this purpose, the DiveTracker™ Sport transmitter (DTS-TX) can be configured to emit pulses anywhere from one to fifteen times per second. When you use the DiveTracker™ Sport receiver, you will be able to distinguish between the several transmitters by watching how fast the LED strip is blinking.

The transmitter pulse repeat rate is controlled by a four position 'DIP switch' that is located on the inside of the housing. The DIP switch is factory configured so that your transmitter will emit four sonar pulses per second.

To change the pulse repeat rate, remove the front cap of the transmitter (see chapter 'How to change the DTS-TX battery'). Now look into the opening, holding the housing such that the battery pack is at the bottom. You will notice the DIP switch with its four levers in the top left corner of the opening.

Toggle the switches such as to achieve the desired pulse rate. The switch positions and associated pulse rates are indicated by the following table.

Lever 4	Lever 3	Lever 2	Lever 1	PPS -
UP	UP	UP	UP	0
UP	UP	UP	DOWN	1
UP	UP	DOWN	UP	2
UP	UP	DOWN	DOWN	3
UP	DOWN	UP	UP	4 –
UP	DOWN	UP	DOWN	5
UP	DOWN	DOWN	UP	6
UP	DOWN	DOWN	DOWN	7
DOWN	UP	UP	UP	8
DOWN	UP	UP	DOWN	9
DOWN	UP	DOWN	UP	10
DOWN	UP	DOWN	DOWN	11
DOWN	DOWN	UP	UP	12
DOWN	DOWN	UP	DOWN	13
DOWN	DOWN	DOWN	UP	14



DOWN	DOWN	DOWN	DOWN	15
------	------	------	------	----

notes:

-: Pulses Per Second

--: Factory Setting

## DTS-TX Switch Settings and Associated Pulse Repeat Rates

Since it very hard to distinguish between closely spaced pulse rates, we suggest that you only use pulse rates of one time, two times, four times and eight times per second.

If more than two DiveTracker™ Sport are 'in view' of a receiver, you will pick up the signals from both units. This will result in irregular LED strip blinking.

## 5.2 Advanced Receiver Operation Options

Two special operation options are selected through small toggle switches located to the left of the LED strip display on the inside of the DiveTracker™ Sport receiver (see drawing in section 4.2).

The switches are factory configured in the DOWN position, where they should remain unless you have a specific reason to change the configuration:

The left switch (switch 1) selects 'extended range'. Raise the lever to the UP position to double the range of the receiver. In 'normal range' mode, your receiver will have a range of 1000 to 2000 feet. In 'extended range' mode, the range is increased to 2000 to 4000 feet. The disadvantage of extended range operation is a loss in ability to distinguish echoes from the direct signal at close range. We recommend that you use the 'normal range' setting unless you specifically expect to venture more than 1000 feet from the location of the transmitter. The distance scale on the receiver is calibrated for 'normal range' operation. Multiply the readings by two to obtain a distance estimate in 'extended range' operation.

The right switch (switch 2) controls the 'persistence' of the LED strip display. The LED strip lights up whenever a SONAR signal is received. However, since a SONAR pulse lasts only four thousands of a second, the display 'remembers' the pulse and keeps the display on for a while longer. If you flip the switch UP, this 'memory' will be increased by a factor of two. In this 'extended persistence' mode, the display will be less 'flickery' but you will also lose some of the ability to distinguish between different pulse repeat rates (see section 5.1.).

## 5.3 Advanced Navigation

In chapter two, we explained the basic use of the DiveTracker™ Sport receiver - hold the receiver horizontally and look at the LED strip. Then, slowly rotate your body around its axis so that the directional sonar transducer at the bottom of the housing gets a good view of your surroundings. Notice the direction at which the receiver picks up the strongest signal (the most LEDs light up). That direction is the most likely direction of the transmitter marked site.

We also told you that you could determine whether you are getting closer or further away from the transmitter by checking if the signal is getting stronger or weaker.

While DiveTracker™ Sport can be operated in this manner; it is far more effectively used in conjunction with a compass. The combination of the two instruments lets you accomplish a variety of navigation tasks. Some ideas are provided here. You can probably invent several other uses.

### **Finding the Transmitter (Returning to the Dive Start Point)**

Returning to the start point of your dive or finding any transmitter marked site is accomplished easily using DiveTracker™ Sport and a compass.

- Determine the direction of the strongest signal and notice the compass bearing. Follow the bearing.
- Periodically stop and re-determine the bearing producing the strongest signal, correct your course accordingly.
- You will know that you overshot the target if you obtain a compass bearing that is opposite to previous readings.
- If you are getting no clear direction of maximum strength, point the receiver up (or down). You are probably right underneath the transmitter.

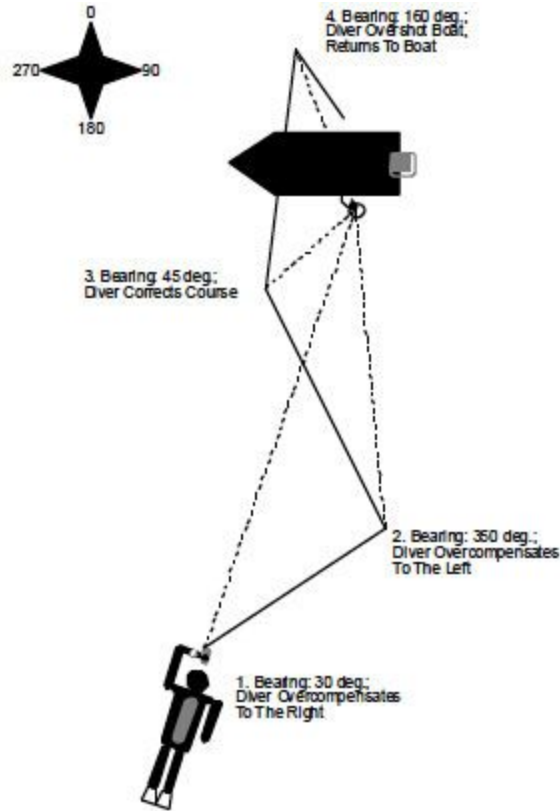

### DiveTracker™ Sport Aided Compass Navigation

The above technique will send you on an 'auto-correcting' course: If you have chosen a course to the left of the transmitter, the system will ask you to correct to the right when you take your next reading. Thus, you will approach the transmitter in a zigzag fashion.

### Finding and Recording Your Position

One simple method of estimating your current position is to note the DiveTracker™ Sport provided bearing back to the transmitter location (boat). If that bearing is 180° (south), you are to the north (0°) of the transmitter. If the bearing is 270°, you are  $270 - 180 = 90^\circ$  (east) relative to the transmitter.

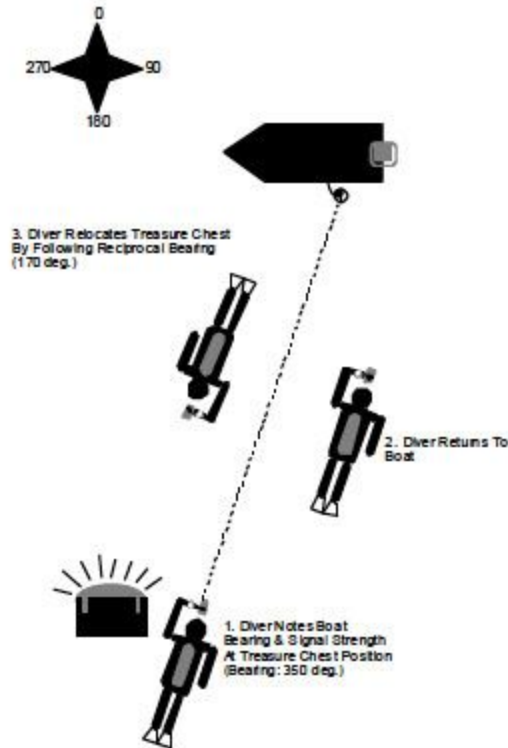

Recording a Position

To 'record' your current position, notice the bearing back to the transmitter site as well as the signal strength. After returning to the boat, you can relocate the site by swimming out on a reciprocal (plus or minus 180 degrees) course until you see the signal strength that you recorded on your previous dive.

### Using Sonar Triangulation to Fix a Position

To record and relocate a position more accurately, you may apply a technique known as sonar triangulation. This technique is the underwater equivalent to the practice of 'taking sightings' to fix a position at sea or on land.

Sonar triangulation requires that you deploy two or more DiveTracker™ Sport transmitters (DTS-TX). Typically, you will secure one transmitter close to your dive boat, while a second transmitter is mounted on a buoy some distance away from the boat. These two transmitters form a 'sonar baseline'.

Now, start your dive. When you find what you were looking for (the treasure chest), use your DiveTracker™ Sport receiver and your compass to determine the bearing both back to the boat and to the second transmitter. To re-locate the site on a future dive, swim from the boat at a bearing that

is reciprocal (plus or minus 180 degrees) to the previously recorded bearing of the boat as seen from the site of the treasure chest.

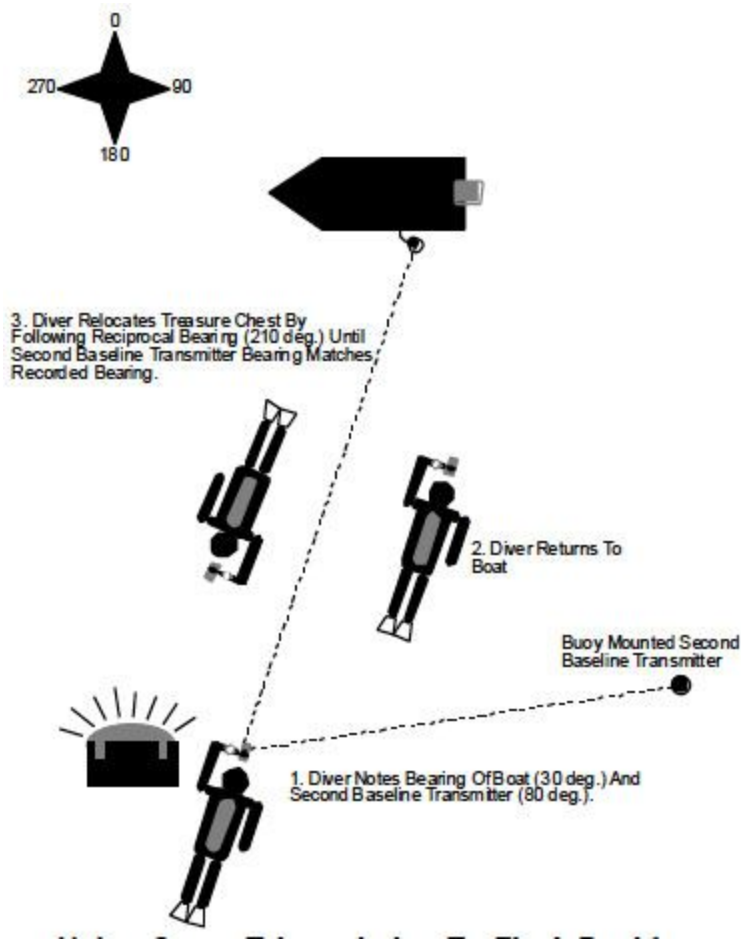

Using Sonar Triangulation to Fix a Position

Stop periodically to make sure you are still on the right course. At each stop, also determine the bearing of the second transmitter marked site. You will notice that that bearing will start approaching the bearing of the second transmitter as recorded on your previous dive. Once both bearings match your recording, you are in the vicinity of the recorded site.

To distinguish between multiple DiveTracker™ Sport transmitters, set the transmitters to different pulse repeat rates as described in section 5.1.

You will get best accuracy when the two transmitters are at approximately right angles (90 degrees) as seen from your position. If the angle approaches either 180 degrees or zero degrees, accuracy will get progressively worse.

Thus, make the baseline of sufficient size and set it up such that your diving is broadside to the baseline rather than off either end of the baseline.

### **Using Math to Enhance Navigation Capabilities**

You have seen that DiveTracker™ Sport gets to be a whole lot more useful when used in conjunction with a compass. Additional functionality can be achieved by also adding a scientific calculator, a straight edge and some pencils and paper to your navigation toolbox. These techniques require a decent math and geometry background, which is beyond the scope of this booklet.

While the following list doesn't tell you how it's done, it tells you what can be done. Check out some books on surveying, nautical navigation, and geometry if you are curious.

### **Advanced DiveTracker™ Sport Navigation Techniques**

- Transferring recorded positions to a map.
- Obtaining your latitude and longitude.
- Calculating the maximum position error and drawing a region of uncertainty.
- Following a precise search pattern

Of course, DiveTracker™ Sport does have its limitations. If your navigation requirements should outpace this instrument and if your pocket book is sufficiently deep, call us for information on our DiveTracker™ DTX system. This system design is for the professional diver and can get you within six inches of a target position. It also allows you to track multiple divers from the surface, observe diver depth and remaining air supply of each diver in real-time, communicate with the divers, conduct precise surveys, electronically record diver observations, and sensor readings, and perform custom decompression and other computing jobs. Below, a view of the DiveTracker™ DTX surface-station computer screen including the traces of two divers is shown.



View of a Dive Site Generated By the DiveTracker™ DTX System

## 6. Beware Of the Sonar Gremlins

DiveTracker™ Sport is a SONAR based navigation system. As such, it makes use of the advantageous sound propagation conditions under water. However, it is also subject to the limitations of sonar technology.

While DiveTracker™ Sport will in general provide you with good and reasonably accurate information, there are conditions that can interfere with the operation of the system. It is to your advantage to know under what conditions DiveTracker™ Sport can fail, and under what conditions the system will provide false information. This chapter introduces you to the basics of SONAR science and tells you what to watch out for and how to fix a problem should it arise.

DiveTracker™ may fail for three principal sonar related reasons.

### **SONAR Related DiveTracker™ Failure Conditions**

- DiveTracker™ Sport will fail if the SONAR energy from the transmitter does not reach your receiver.
- DiveTracker™ Sport will fail if underwater noise obscures the signal of the transmitter.

- DiveTracker™ Sport will provide you with false bearing information if there is no direct sonar path or if a SONAR echo is stronger than the direct signal.

The following three sections show what causes these failure conditions and how to deal with them.

## 6.1 The Siren Call of SONAR Echoes

Whenever sound hits the border between two mediums, it is reflected and refracted (bend). This effect is the greatest whenever there is a big difference in the speed of sound in the two media. For example, the ocean surface is a great sound reflector because sound travels in the air above the ocean so much slower than it does in water. However, sound is also reflected and refracted by the sea floor, by rocks, kelp, layers of water with different temperature (thermoclines) or salinity, the hulls of ships etc.

Any sound obstacle will serve as a partially reflective and partially transparent mirror - some sound will pass through it (but will change direction), some will be reflected and some may be absorbed (turned into heat) altogether.

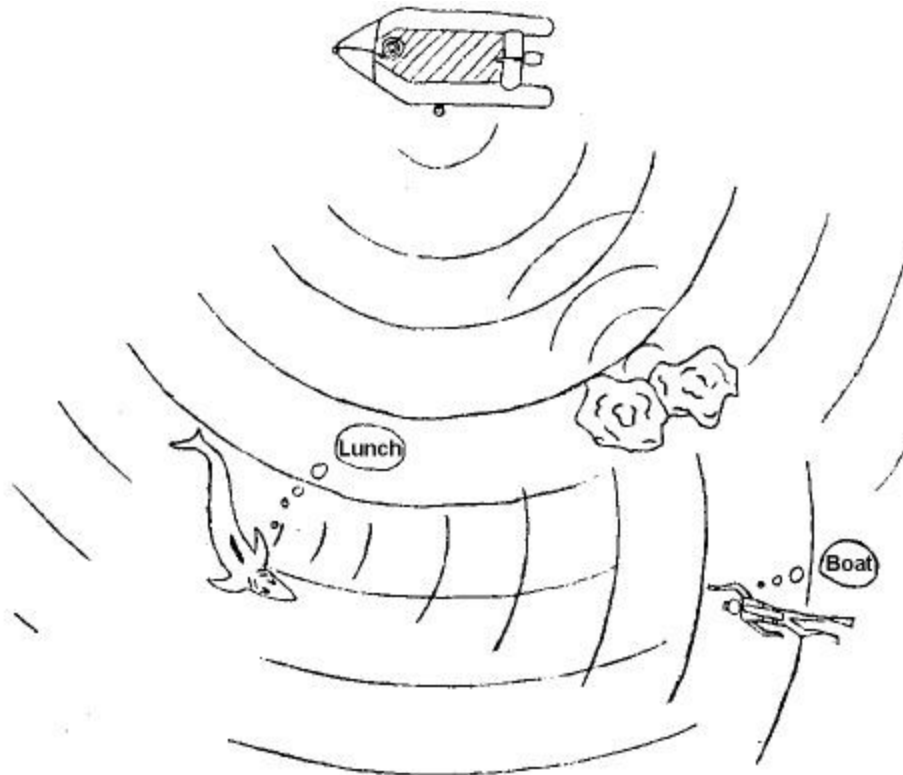



## Echo Misleads A Diver

The effect of SONAR reflection is that you will see echoes. When you follow an echo rather than the direct sonar signal, you will be led to the source of that echo, be that a rock, some kelp, a water turbulence, or the snout of a giant shark.

Frequently you will receive signals from multiple directions. Fortunately, however it is usually possible to distinguish between a misleading echo and the direct signal: The direct signal is usually also the strongest signal. So, whenever you obtain multiple sonar signals, carefully look at the LED strip to determine which signal is the strongest one. A difference of one or two LED segments can be of significance here! If you get very strong signals from many directions, switch the receiver knob to LO gain. This will reduce the receiver sensitivity and will improve your ability to measure the relative strengths of very strong (close by) signals.

In some cases, the strongest signal is not the direct signal but an echo. It is also possible that you are blocked entirely from the direct signal and that all signals are echoes.

*If you follow an echo, you will be led in the wrong direction.*

When echo activity gets to great and you are within an obstructed area, it helps to move away from the obstructions into clear water in order to obtain a better reading.

## 6.2 Loss of Signal

DiveTracker™ Sport will not work if the sonar energy from the transmitter does not reach you. When a loss of signal occurs, the LED strip will not start blinking no matter which direction the receiver is pointed. There can be several reasons for a loss of signal.

### **Possible Causes of Signal Loss**

- The SONAR signal is blocked by terrain features such as a reef.
- The SONAR signal is reflected off thermocline.
- Your distance from the transmitter is too great.

The solution to a loss of signal condition depends on the specific situation.

## How to Deal with Signal Loss

- If the sonar energy bounces off a thermocline, lower the transmitter so that it is located below the thermocline.
- If the sonar path is blocked by terrain features, re-position yourself so that you are within 'line of sight' of the sonar transmitter.
- If the distance from the sonar transmitter is too great, get closer (we know, that may be easier said than done).

A second problem related to the 'loss of signal' issue is that some sonar conditions may fool you into believing that you are either much closer or much further away from the transmitter than you really are. For example, if you are below a thermocline and the transmitter is above the thermocline you may pick up a signal that is much weaker than would otherwise be the case. This may lead you to believe that you are at a much greater distance from the transmitter than you really are.

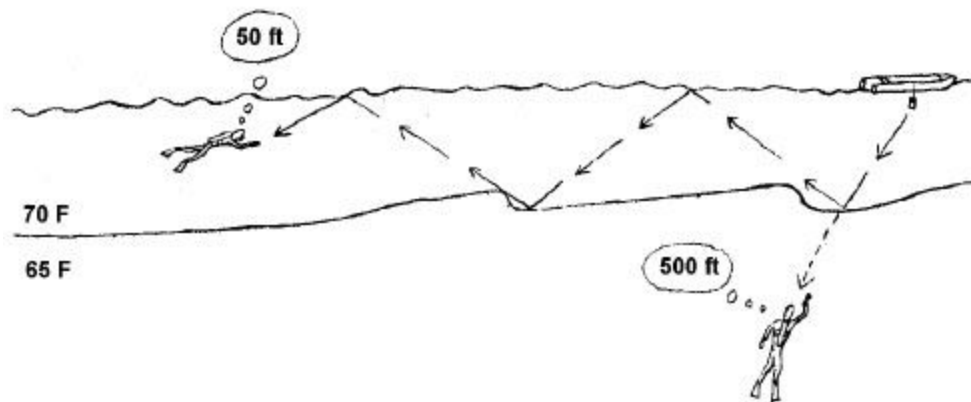

The Effects of SONAR Signal Blockage and Ducting

In a similar fashion, a SONAR phenomenon known as 'ducting' can cause SONAR energy to be trapped between layers of water and travel in that duct long distances without fading as much as would usually be the case. Consequently, you may pick up a very strong signal and believe that you are closer to the transmitter than you really are.

In addition to all these problems, it is also possible for the transmitter signal at your location to experience strong fluctuations in strength even though you are not moving.

Be aware of these potential pitfalls and take them into consideration when planning and executing your dive!

## 6.3 The Noisy Ocean

The ocean is a noisy environment. A variety of animals including snapping shrimp (no, we are not referring to your vicious child), sea urchins, dolphins, croaker fish and whales raise a cacophony of sounds. Man adds to this with the drum of boat engines, the hissing of SCUBA regulators, the pinging of depth sounders and DiveTrackers™, and the banging of man and machine at work in harbors.

The signals of DiveTracker™ have to find their way through all that racket and still be heard. To aid in this task, your DiveTracker™ receiver is equipped with a high quality band-pass filter. The filter removes virtually all the noise except signals located in the small frequency band around 72.5 kHz, which is used by the DiveTracker™ transmitter. As a result, most ocean noise will not interfere with your DiveTracker™.

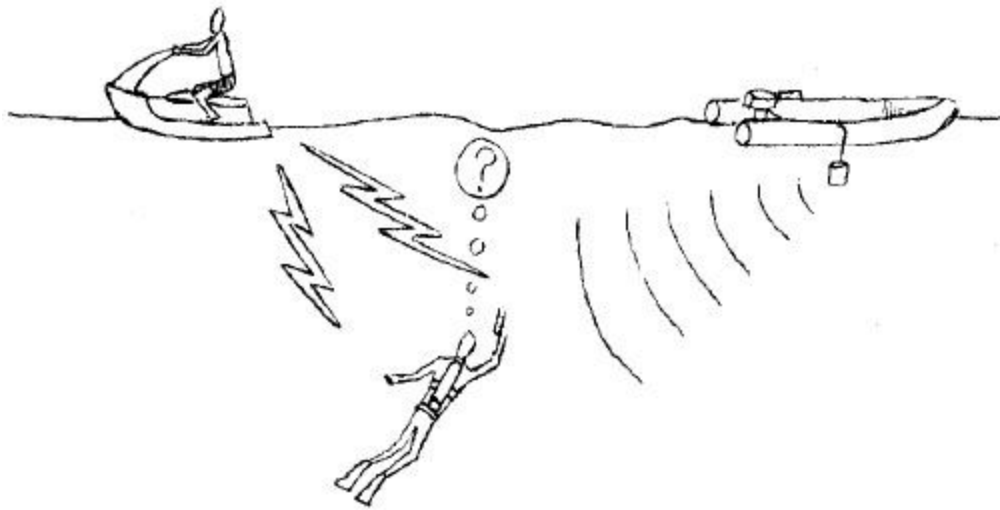

**Strong Noise Can Disrupt System Operation**

Two noise sources that may give you trouble however are the noise of motor boats passing in close proximity as well as the hissing of your own SCUBA regulator when you inhale. In either case, you are only likely to be bothered by that noise if your DiveTracker™ receiver is in the **HI** gain setting.

It is rare for noise to have the same periodic pinging characteristic as the DiveTracker™ signal. Thus, you will usually be able to tell noise from 'the real thing' by the way it registers on the LED strip indicator.

If you do have trouble with regulator noise, make a point of taking your readings while you are not inhaling - ignore readings taken while you are inhaling. If the trouble is boat noise, you will have to wait until the boat has passed.

## **7. Technical Specifications**

<u><b>Transmitter</b></u>	
<b>Order Number:</b>	DTS-TX
<b>Transmit Power:</b>	4 W RMS, electrical
<b>Pulse Sequence:</b>	0 to 15 4 ms pulses per second, switch selectable
<b>Radiation Pattern:</b>	Omni Directional
<b>Frequency:</b>	72.5 kHz, +/- 7.25 Hz
<b>ON Switch:</b>	Magnetic thumb wheel
<b>Power:</b>	Six AA alkaline cells
<b>Battery Life:</b>	168 hours, nominal at 4 pulses / second
<b>Low Battery Indicator:</b>	Red LED
<b>Size:</b>	Cylinder, 2.5" D x 5.0" L
<b>Weight:</b>	22 ounces in air, 4 ounces in water
<b>Operating Temperature:</b>	0°C to 70°C
<b>Depth Rating:</b>	1000 feet
<b>Construction:</b>	Precision machined out of solid PVC

<u><b>Receiver</b></u>	
<b>Order Number:</b>	DTS-RX

<b>Receiver Range:</b>	1000-2000 feet in normal range mode (typical) 2000-4000 feet in extended range mode (typical)
<b>Beam Pattern:</b>	29° @ -3 dB, conical
<b>Center Frequency:</b>	72.5 kHz
<b>Filter:</b>	4th order active, Q=25
<b>ON Switch:</b>	Magnetic thumb wheel
<b>Gain Control:</b>	HI/LO gain via ON switch, internal 'extended range' switch
<b>Signal Strength Indicator:</b>	9-element LED strip, 3 dB per LED, selectable persistence
<b>Distance Indicator:</b>	Dual scale above LED strip
<b>Low Battery Indicator:</b>	Red LED
<b>Power:</b>	9V alkaline battery
<b>Battery Life:</b>	6 hours continuous operation or about 70 dives at ten readouts per dive
<b>Size:</b>	Cylinder, 2.5"D x 5.0"L
<b>Weight:</b>	17 ounces in air, 3 ounces in water
<b>Operating Temperature:</b>	0°C to 70°C
<b>Depth Rating:</b>	1000 feet

**Construction:**

Precision machined out of solid PVC &amp; Lexan

Technical specifications are subject to change without notice

## 8. Warranty

Your DiveTracker™ Sport is a high-quality product that has been designed and manufactured in the United States of America. Like all Desert Star Systems products, it is backed up by a one year limited warranty. To make a warranty claim, just return your DiveTracker Sport with a brief description of the problem to the place of purchase. If you purchased directly from Desert Star Systems, please call the factory at 831-384-8000 and request an 'RMA number'. Write the number onto the outside on the package, and note it in any paperwork. It is the reference number for the service.

The greatest danger to your DiveTracker™ Sport is flooding. You can avoid flooding entirely by carefully inspecting and cleaning the O-ring before you close the housing. However, because the risk of flooding depends on your degree of care, we cannot be held responsible for damage due to flooding. Flooding is thus specifically excluded from our warranty.

Desert Star Systems ("Seller") warrants DiveTracker™ Sport to be free from defects in design, workmanship and material under normal and proper use and service for a period of one year following delivery to Buyer. Seller agrees to repair or replace at the place of manufacture, without charge except shipping charges, all parts of said products which are returned, for Seller's inspection, to its factory within the warranty period, provided such inspection discloses that the defects are as above described and provided also that the equipment has not been altered or repaired other than with Seller's authorization and by its approved procedures, subjected to misuse, improper maintenance, flooding, negligence, or accident.

**THIS WARRANTY IS IN LIEU OF ALL OTHER WARRANTIES, EXPRESSED OR IMPLIED, INCLUDING THOSE OF MERCHANTABILITY, PERFORMANCE OR FITNESS FOR PURPOSE.**